



SONESSE 50 WT PA/PS TECHNICAL DATA

TS - FPTE
RANGE 1
ST50 PA PS Range1 R1
16/07/2007 Page 1/2

Nominal voltage	230V - 50 Hz
Power supply tolerances	207 - 253 V
Thermal time	4 minutes
Number of wires of the cable	5
Wire section	0,75 mm ²
Type of Limit Switch Unit	Progressive limit switch
Capacity of the Limit Switch Unit	29 turns
Repeatability	± 8°
System of protection	IP 31
Interface drawings	206810 : Screw Implantation LT50 206821 : Wheel Interface LT50 206822 : Crown Interface LT50 206823 : Star Head LT50, LT50 PA/PS 206863 : Buttons LT50 PA
Basic crown for tube Ø	50 x 1,5 mm + see integration recommendations
Temperature working range	Normal use : 0°C to + 60°C
Noise Level	According to SOMFY measurements (Pressure level measured at 1m from the end product).

Integration recommendations	
	<ul style="list-style-type: none"> * The noise level depends upon the right fit between customers tubes and accessories, especially the crowns and the wheels. * Free plays have to be minimized between the accessories and the end product tube to ensure the performance of the actuator. * Interior tube diameter > 47 mm - compatible with LT50 range crowns and wheels - * Crown as an interface with tubes is compulsory to ensure the performance of the actuator. * The stop wheel (ref : 9910004) must be screwed with a torque ranging between 1.5Nm and 1.8Nm. * Drive wheel must be riveted to the tube. * It's recommended to use the specific collapsable idler end cap (ref : 9013592 or ref : 9013593) for silent result (do not use LT50 idler end caps). * Somfy Soft Clip wheels are forbidden for this application.

Designation	Tests done at 20°C, 230V 50Hz, in a tube of Ø63														
	Nm	rpm		mm	mm	mm	mm	W	A	°C		kg	dBA	mm	µF
	Nominal torque	No-load Speed	reference	L1 max.	L2 (±3 mm)	L3 max.	tube	Rated power	Rated current	Thermal tripping	Brake type	Weight	Noise	Stator	Capacitor
SONESSE 50 WT PS 3/28 VVF 3m	3	28	5047826A	712	701	726	650	90	0,4	120	sliding	2,75	≤44	60	2,5

Neutral	Blue
White adjusting screw	Brown
Yellow adjusting screw	Black
NO contact (yellow AS)	Grey
Earth	Green / Yellow

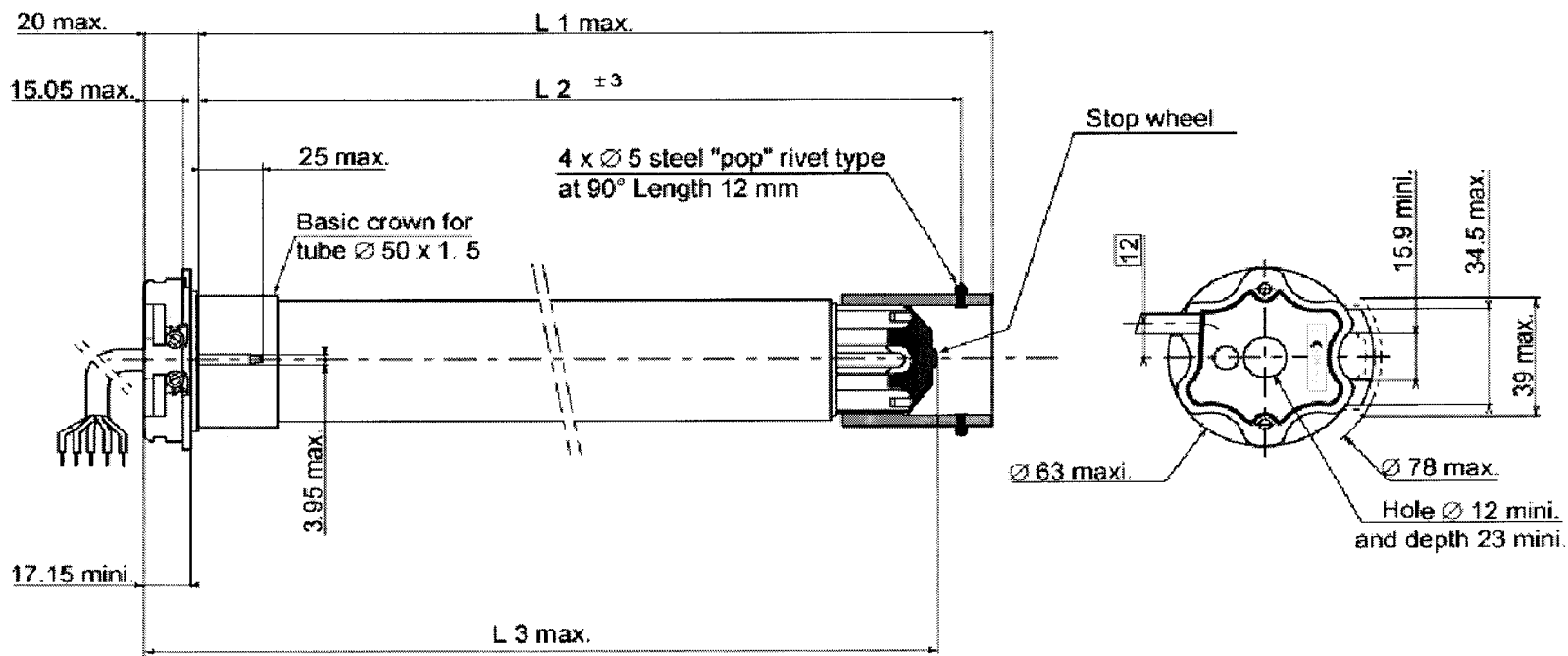

R & D		QUALITY		AUTHOR	
Name	Yann LE RU	Name	Xavier COLET	Name	Arnaud MARTIN
Date	16 07 07	Date	17/07/2007	Date	le 16/7/7
Visa		Visa		Visa	